

CONTROL TECHNIQUES OF HIGH STEP UP CONVERTER FOR PHOTOVOLTAIC SYSTEM

Saurabh H. Thakare¹, Rahul S. Desai²

M.Tech, Electrical Power System, Bharati Vidyapeeth Deemed University College of Engineering, Pune, India¹

Assistant Professor, Bharati Vidyapeeth, Deemed University College of Engineering, Pune, India²

Abstract: In this paper, the comparison between Hysteresis current control technique and SPWM control technique of high step up converter for photovoltaic system is presented with the help of MATLAB simulation. To improve the voltage gain of system and to reduce its Total Harmonic Distortion value in output, Hysteresis current control technique is used for step up converter and voltage multiplier module for the photovoltaic system. Simulation of both the methods SPWM (open loop) and Hysteresis control (closed loop) is done on the basis of THD performance and it is observed that THD percentage are reduced from 3212.66% to 63.96% .

Keywords: High step up converter, control methods of converter, photovoltaic system, Total Harmonic Distortions.

I. INTRODUCTION

The importance of renewable energy resources increases day by day because of their eco-friendly nature and limited sources of non-renewable energy resources. So that the world's focus increases towards the utilization of these energy resources. Photovoltaic systems carries major role in the production of energy than other renewable resources [1]. But these system gives less output so that the step up converters was suggested for such system. Thus, by using such converters low voltage can be converted into high voltage [2]. But the suggested converter are conventional type converter and fails to attain high output. In fact, their efficiency is also less. For this reason, certain modifications were done and the new converter i.e. boost and fly back was suggested to come out from this problem [3]. Also, the converters having inductor coupling for the purpose of improvement of conversion ratio were also suggested. Away from this, conventional converters have single switch and thus produced large ripple in current which increases losses in conduction in case of high rating applications. Thus, the new converter was suggested in case of solar photovoltaic system by using module of voltage multiplier given in [4]. But, in this system SPWM method is used for converters and inverters. This system attains high voltage output but gives more THD losses. Hence, Hysteresis control technique is presented in this paper which will reduce THD percentage. Also, with the help of MATLAB Simulation comparative study is done between both methods.

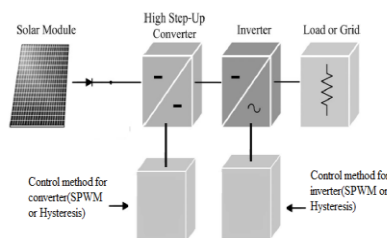

Fig. 1. Block diagram of photovoltaic system

The photovoltaic system consist of high step up converter, inverter, solar module and load. Hysteresis method and SPWM method are the control methods used for converters. The solar model is designed for 40V output[5] and [6].As solar module generates low output, its output is given to the high step up converter. It increases the gain in voltage efficiently upto 380V. The output of converter is given to the inverter and then from inverter it is given to the load. The system contains the module of voltage multiplier which consist of two inductors which are coupled and the boost converter. The inductors which are coupled have primary windings and secondary winding. Primary windings contains N_p turns and they are used for decreasing the ripple in input current. Secondary winding contains N_s turns and they are used to increase gain in the voltage. Also, ‘.’ and ‘*’ is used for referencing the coupling of coupled inductors. The turns ratio are same in coupled inductors. As shown in fig.2 , S_1, S_2 are the switches, L_{k1}, L_{k2} indicates leakage inductors, L_{m1}, L_{m2} denotes magnetize inductors, C_b indicates the capacitor for lifting the voltage and N_s/N_p is ratio of turns which is indicated by n .

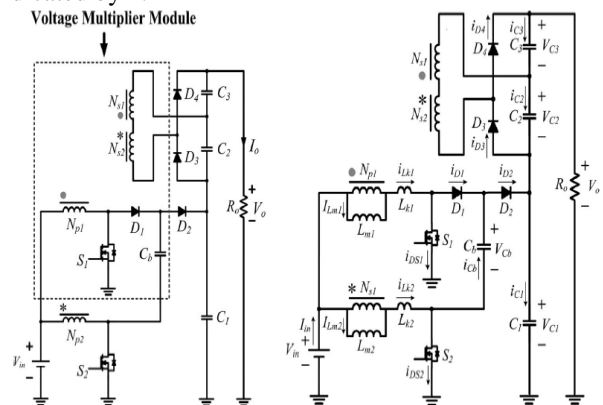

Fig.2.(a) High step up converter with voltage multiplier module (b) High step up converter

II. OPERATION OF HIGH STEP UP CONVERTER

The operation of the converter is performed by using both methods. The operation is performed in six modes. These modes are as follows, Mode I (t0-t1): When t=t0, both switches i.e. S1,S2 gets turned into ON state. Due to this, all diodes are gets in mode of reverse bias. Thus, both magnetize inductors and leakage inductors i.e Lm1,Lm2 and Lk1,Lk2 gets charged by Vin.

Mode II(t1-t2): When t=t1 ,S2 gets switch into OFF state and due to this, both the diodes i.e.D2 ,D4 gets turned into ON state. Due to this, Lm2 shift the energy which is stored in it to other side which then charge C3 . Due to this Vin, Lk2, Lm2 and Cb delivers energy to C1 through diode D2 , it increases the voltage of capacitor C1.

Mode III (t2-t3): When t=t2,the whole energy of Lk2 is delivers to C1.Due to this D2 gets turned into OFF state. Here, the Lm2 shift energy to other side which then charges C3 through diode D4 up to the time of t3 .

Mode IV (t3-t4): When t=t3 ,S2 gets turned into ON state. Hence, each one of the diodes gets turned into OFF state. The operation of mode 4 is nearly same to that of the mode 1 operation.

Mode V (t4- t5): When t=t4 ,S1 gets turned into OFF state and due to this both diodes i.e.D1 ,D3 gets turned into ON state. Hence, Lm1 delivers the energy which is stored in it to other side which then charge C2 .Due to this, both Vin and Lm1 delivers energy to Cb through the diode D1 ,hence more energy gets accumulate in Cb.

Mode VI (t5-t0): When t=t5 ,the whole energy of Lk1 is delivers to Cb. Due to this,D1 gets turned into OFF state. Here Lm1 delivers energy to the other side which then charges C2 through diode D3 up to the time of t0.

III. HYSTERESIS CONTROL METHOD

The dynamic response of Hysteresis control technique is very good..

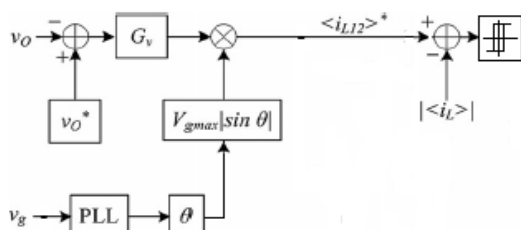

Fig.3.Hysteresis control method

In the above fig., θ indicates phase angle. The value of θ can be find out by using phase locked loop. For v_g greater than 0 ,there is state 1-state 2 combination.

The algorithm for the control of converter is used to find out inductor current correctly for stabilizing the input power of states 1-state 2 union. States 1-state 2

combination is for boost mode. Also, By using product of G_v output and PLL output, controller produces $i_{L12} * G_v$ consist of PI compensator. The designing of G_v is done in such a way that it is suitable for operation modes. This method is suitable for high rating applications. This is the main reason for selecting this method.

IV. RESULTS AND DISCUSSIONS

The simulation modeling is done by using both SPWM method and Hysteresis control method as shown in fig 4 and fig 5 respectively. In case of SPWM method, the pulses are given to converter and inverter with the help of pulse width modulation function. This function is inbuilt in pic microcontroller. The simulation model for step up converter by using SPWM method is shown in fig.4 . In Hysteresis control method, pulses are given with the help of relay block. The simulation model for high step up converter by using Hysteresis control method is shown in fig.5. The control topology is shown in fig.6. Also, the hysteresis control method has fast response as compare to the SPWM method.

In case of SPWM method, switching frequency is low hence not suitable for high rated application and it is restricted to only low rated application. But in case of hysteresis control method, switching frequency is more hence suitable for high rated applications also.

The THD% level is high in case of SPWM (open loop) method whereas in case of hysteresis control method (closed loop), THD% is decreased .Thus, THD % is decreased by using Hysteresis control method. This is shown in fig.7.

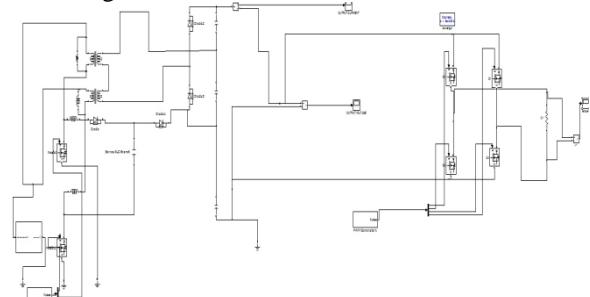

Fig.4. Simulation model for high step up converter using SPWM method

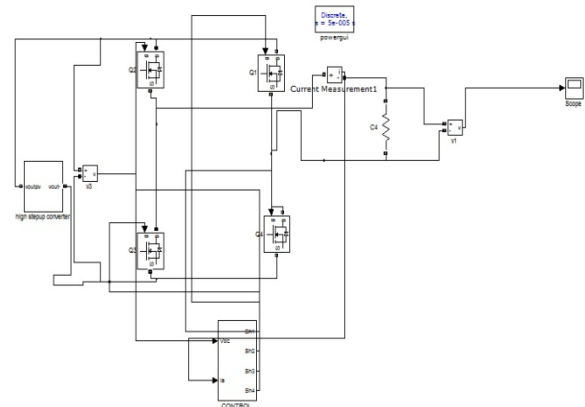

Fig.5. Simulation model for high step up converter using hysteresis control method

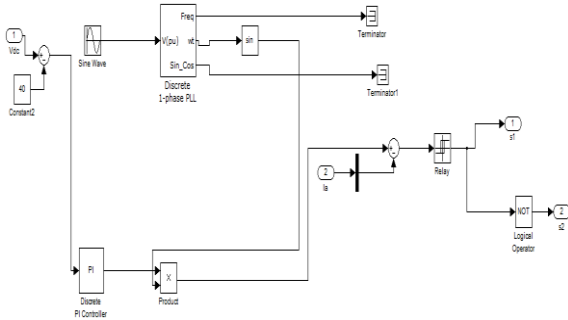

Fig.6. Control topology for controlling converter and inverter

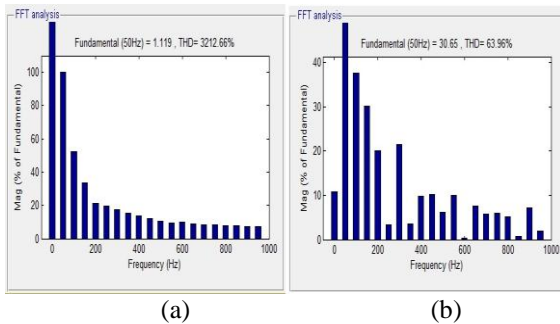

Fig.7. Simulation results of THD performance for both methods (a) SPWM method (b) Hysteresis control method

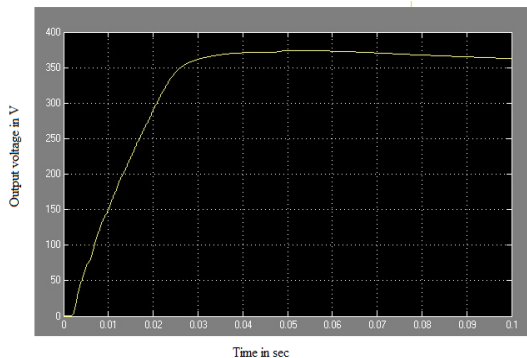

Fig.8. Output voltage of high step up converter obtained required gain nearly 380V

V. CONCLUSION

Comparison is done between both the control methods i.e. SPWM method and Hysteresis method for high step up converter for photovoltaic system with the help of MATLAB Simulink and study is performed accordingly. From Simulation results it is observed that THD% is 3212.66% in SPWM (open loop). But it gets reduced from 3212.66% to 63.96% in hysteresis control method (closed loop). Also, the required voltage gain obtained is 380V for 40V input by using both control methods.

REFERENCES

- [1]. Kuo-ching Tseng, Chi-chih Huang, Wei-Yuan Shih, "A high step up converter with voltage multiplier module for a photovoltaic system," IEEE Trans. on power electronics., vol.28, No.6, June 2013.
- [2]. Ching Tsai Pan and Ching Ming Lai, "A high-efficiency high step-up converter with low switch voltage stress for fuel-cell system applications," IEEE Trans. Ind. Electron., vol. 57, no. 6, pp. 1998–2006, Jun. 2010
- [3]. Wuhua Li, Yi Zhao, Jiande Wu, Xiangning He, "Interleaved High Step-Up Converter With Winding-Cross-Coupled Inductors and

Voltage Multiplier Cells," IEEE Trans. on power electronics, vol. 27, no. 1, Jan 2012

- [4]. J. T. Bialasiewicz, "Renewable energy systems with photovoltaic power generators: Operation and modeling," IEEE Trans. Ind. Electron., vol. 55, no. 7, pp. 2752–2758, Jul. 2008.
- [5]. M.G. Villalva, J.R. Gazoli, E. Ruppert F, "Modeling and circuit-based simulation of photovoltaic arrays," Brazilian Journal of Power Electronics, 2009 vol. 14, no. 1, pp. 35–45, ISSN 1414-8862.
- [6]. Rajasekhar S, "Solar photovoltaic power conversion using modular multilevel converter" senior member IEEE in 2012.
- [7]. Jong-Won Shin, Hojoon Shin, Gab-Su Seo, Jung-Ik Ha, and Bo-Hyung Cho, "Low-Common Mode Voltage H-Bridge Converter with Additional Switch Legs," IEEE Transactions On Power Electronics, Vol. 28, No. 4, April 2013.

BIOGRAPHIES



Mr. Saurabh H. Thakare :- He received his B.E. degree from the University of Pune, India. He is pursuing M.Tech degree in Electrical Power System from Bharati Vidyapeeth Deemed University College of Engineering, Pune, India. His area of interest are renewable energy sources, power system and photovoltaic system.



Prof. Rahul S. Desai :- He is an assistant professor at Bharati Vidyapeeth Deemed University College of Engineering, Pune, India